

DiamondAir 20.5 SEER2 9K BTU Ceiling Cassette Mini Split

Set Model

Indoor unit model DF2009CI
Outdoor unit model D2009SHO2

Certified

AHRI



UL



SYSTEM PERFORMANCE DATA

Power supply

Normal Operational Voltage (V, Ph, Hz) 208/230V, 1Ph, 60Hz
Voltage Range (V) 187-253

Electrical

Minimum circuit ampacity(Outdoor) (A) 15.0
Max.fuse(Outdoor) (A) 15.0
Connection wiring 14*4 AWG

Cooling

Capacity (Btu/h) 9000(2850~11100)
Power Input (W) 692(163~1117)
Current (A) 3.17(1.25~4.93)
SEER2 (Btu/W) 20.5
EER2 (Btu/W) 13.0

Heating

Capacity (Btu/h) 9800(2270~12500)
Power Input (W) 930(149~1371)
Current (A) 4.58(1.17~6.04)
HSPF2-4 (Btu/W) 10.3
HSPF2-5 (Btu/W) 7.8
COP W/W 3.09
Heat at 17F(H32) (Btu/h) 9000
Heat at 5F(H42) (Btu/h) 10000
COP at 5F(H42) W/W 1.80

REFRIGERANT PIPE DATA

	Indoor unit	N/A
Throttle type	Outdoor unit	EXV
Design pressure (PSIG)		550/340
Refrigerant Type		R410A
Refrigerant charge (oz)		41.62
Refrigerant precharge (ft)		25.0
Additional charge for each ft (m)		7.5
Additional charge for each m (oz/ft)		0.16
Additional charge for each m (g/m)		15.0
Liquid side/ Gas side(indoor) (inch)		1/4" / 3/8"
Liquid side/ Gas side(indoor) (mm)		6.35/9.52
Liquid side/ Gas side(outdoor) (inch)		1/4" / 3/8"
Liquid side/ Gas side(outdoor) (mm)		6.35/9.52
Max. pipe length (ft)		82.0
Max. pipe length (m)		25.0
Max. difference in level (ft)		32.8
Max. difference in level (m)		10.0
Connection method		Flared
Indoor(cooling) (Deg. °F)		62~90
Indoor(cooling) (Deg. °C)		17~32
Indoor(heating) (Deg. °F)		32~86
Indoor(heating) (Deg. °C)		0~30
Outdoor(cooling) (Deg. °F)		-22~122
Outdoor(cooling) (Deg. °C)		-30~50
Outdoor(heating) (Deg. °F)		-22~75
Outdoor(heating) (Deg. °C)		-30~24

INDOOR UNIT DATA

Indoor fan motor

Model ZKFP-46-8-1
Qty 1
Input (W) 45.00
Output (W) 46.0
RLA (A) 0.00
Speed(Hi/Mid/Lo) (r/min) 600/520/460

Air flow & Noise level

Indoor air flow (Hi/Med/Lo) (No duct) (CFM) //352.94/305.88/270.59
Indoor noise level (Hi/Med/Lo) [dB(A)] 39.5/36/32.5

Dehumidification

(L/H) 1.03

Indoor unit

Dimension (WxDxH) (inch) 22.44x22.44x10.24
(mm) 570x570x260
Packing(WxDxH) (inch) 26.06x26.06x12.48
(mm) 662x662x317
Net/Gross weight (lbs.) 31.97/38.14
(kg) 14.5/17.3

OUTDOOR UNIT DATA

Compressor

Type ROTARY
Model KTN110D42UFZ
Brand GMCC
Capacity (Btu/h) 11823
Input (W) 885
Rated current (RLA) (A) 8.8
Refrigerant oil/oil charge (ml) VG74/350

Outdoor fan motor

Model ZKFN-34-10-1
Qty 1
Input (W) /
Output (W) 34.00
RLA (A) 0.42
Speed (r/min) 850/680/450

Air flow & Noise level

Outdoor air flow (Max.) (CFM) 1323.5
Outdoor noise level [dB(A)] 55.0

Outdoor unit

Dimension (WxDxH) (inch) 31.69x12.99x21.81
(mm) 805x330x554
Packing (WxDxH) (inch) 36.02x14.57x24.21
(mm) 915x370x615
Net/ Gross weight (lbs.) 74.07/80.25
(kg) 33.6/36.4

Indoor unit dimension

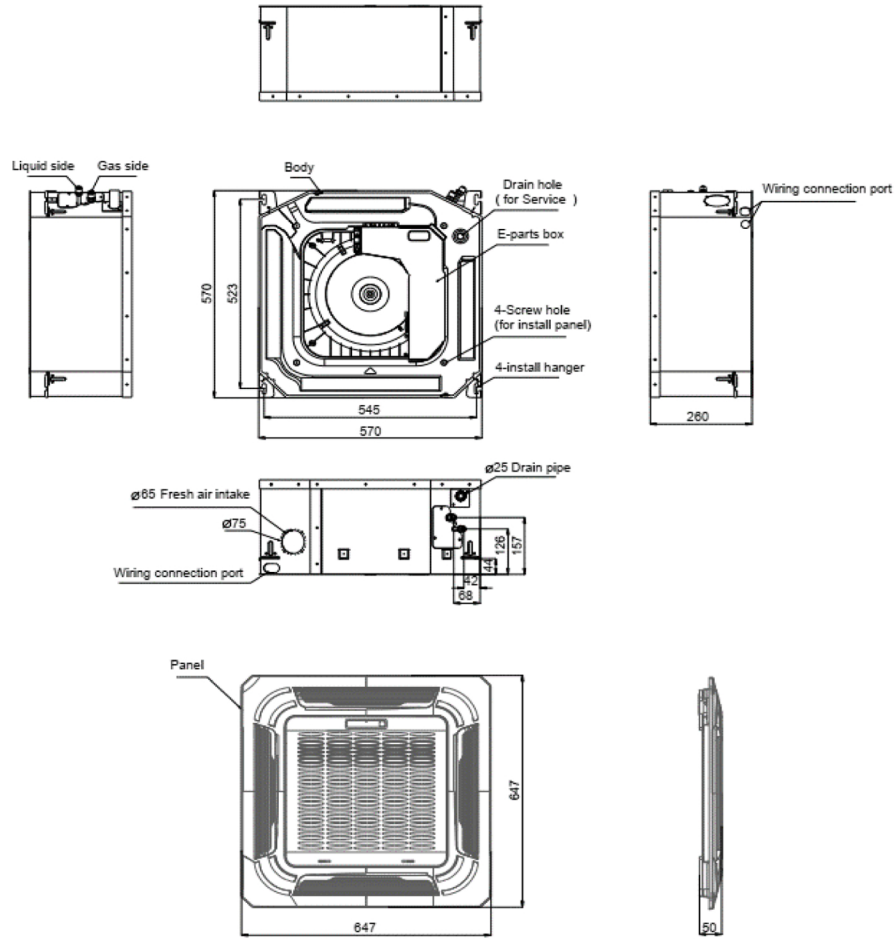

Outdoor unit dimension

